

.....28 March 2017

AES – 3C Maritza East I EOOD

and

Maschinenfabrik Liezen und Gießerei Ges.m.b.H.

SUPPLY OF PRIMARY BEATERS FOR COAL MILLS TYPE N440.41V

CONTRACT NUMBER: 018-17-PPL

This Contract is made on this 24th day of Nov, 2017

BY AND BETWEEN:

- (1) **AES – 3C Maritza East I EOOD**, a one-person private limited company registered in the Commercial Register with the Registry Agency under Unified ID Code (UIC) 123533834, having its headquarters and registered office in the town of Galabovo 6280, Galabovo Municipality, Stara Zagora region, Bulgaria, represented by Todor Belezchkov, in his capacity as Plant Manager AES Bulgaria (hereinafter referred to as the "**Contracting Entity**") of the one part

AND

- (2) **Maschinenfabrik Liezen und Gießerei Ges.m.b.H**, a company registered in Austria under VAT number ATU 37070209, having its headquarters and registered office at Werkstraße 5, 8940 Liezen - Austria, represented by Kreuzbichler Rene, in his capacity as Head of sales department foundry division (hereinafter referred to as the "**Contractor**") of the other part,

(each a "**Party**" and collectively the "**Parties**").

WHEREAS:

- (A) The Contracting Entity owns and operates a coal-fired power plant called TPP "AES Galabovo", located on the site of the Contracting Entity (as defined below) at Galabovo 6280, Galabovo Municipality, Stara Zagora region;
- (B) This document and the attachments shall constitute the agreement between the Contracting Entity and the Contractor in respect of supply of Goods

THE PARTIES HAVE AGREED AS FOLLOWS:

GENERAL PROVISIONS:

1. Definitions and Interpretations

In this Contract, the following words and expressions will have the following meanings:

„Contracting Entity“ means the Party designated as such herein, including its legal and private successors.

„Due diligence“ means that level of skill, diligence, prudence, foresight, care and working practices that should reasonably and ordinarily be expected from a skilled and experienced provider, meeting the requirements of the applicable law (dealing with the same type of activity as that of the Contractor under the same or similar circumstances).

„Delivery Date“ means the agreed date or deadline for delivery.

„VAT“ means value added tax, the amount of which is defined in the Value Added Tax Act.

"Delivery" means the delivery to and unloading of Goods under this Contract on the site of the Contracting Entity or any other place designated by the Contracting Entity, or specified herein as the place of supply of Goods as well as carrying out installation and/or other related supply activities to the satisfaction of the Contracting Entity. "Supply" and "Delivered" shall be construed accordingly.

„Binding provisions“ include any law, statute, rules, regulations or regulatory powers, delegated authority or other arrangements, with any amendments thereto, and any other acts the adoption of which such provisions provide for.

„PPA“ means the Public Procurement Act.

„Contractor“ means the party designated as the contractor under a public procurement contract in accordance with decision 52... / 24.03.17 on the ranking of tenders and selection of a contractor by the Contracting Entity, and which is engaged by the Contracting Entity to deliver Goods including its legal and private successors.

"Intellectual property" means copyright and all rights granted under any law or regulation or any other binding act in respect of inventions (including patents) registered and unregistered trademarks, registered and unregistered designs, schemes and confidential information, and all other rights resulting from intellectual activity in the industrial, scientific, literary or artistic fields.

"Required Approvals" means all permits, licenses, permissions, consents, approvals and certificates (whether by law or not) which are necessary to meet any of the obligations of the Contractor under this Contract pursuant to the law or as a result of third party rights.

"Unforeseen circumstances" means circumstances that have arisen after the conclusion of the Contract and are not the result of an act or omission of the Parties, which could not have been foreseen through due care and which renders execution of the agreed terms impossible.

"Total Contract price" or "Price" means the price of this contract agreed to be paid by the Contracting Entity to the Contractor under the Contract in accordance with the terms hereof and their respective amendments (if any).

"Site of the Contracting Entity" means TPP "AES Galabovo" located at the address of the Contracting Entity.

"Subcontractor/s" means the person or persons specified in the tender of the Contractor as a subcontractor, or any person, whom the Contractor has assigned to deliver part of the Goods as a subcontractor in accordance with the provisions of the Public Procurement Act.

"Purchase Order" or "Order" means a delivery order set to the Contractor with a Purchase Order Form. **"Business Day"** means any day other than Saturday, Sunday and a public holiday.

"Payment timeframe" means the period indicated in Article 3.3 hereof, unless a longer period has been specified in the offer the Contractor. In this case, the period specified in the offer shall apply.

"Goods" means all Goods to be delivered under this contract together with all accessories and/or services accompanying their delivery according to technical specification of the Contracting Entity.

"Technical specification" means a technical specification and conditions of the Contracting Entity, which is an attachment to and an integral part of the Contract.

"Force majeure" means fire, explosion, earthquake, extremely harsh weather conditions, war, hostilities, rebellion, revolution, insurrection, military or usurping power, civil war, terrorist attack, events caused by aircraft or objects dropped by them, civil unrest, riots, government actions, unexpected or unforeseen at the date of this contract, or any

combination of the above factors insofar as these are beyond the reasonable control of a Party and prevent the Party from meeting its obligations arising from this contract. "Force majeure" will also be considered any circumstances constituting force majeure within the meaning of Art. 306 of the Commercial Act.

The headings herein shall only be indicative.

2. Subject of the Contract

The Contracting Entity assigns and the Contractor agrees against the price mentioned hereunder to transfer ownership and deliver to the Contracting Entity the Goods specified in the Special Conditions (Appendix 1), the Technical Specification (Appendix 2).

3. Goods price and payment

- 3.1. The price of the Goods is the amount specified in the Special Conditions (Appendix 1). This price is the final and maximum price payable by the Contracting Entity for the entire duration of this Contract and subject to adjustment only in the cases expressly provided for in the legislation.
- 3.2. The price under Article 3.1 includes all costs of the Contractor, including transportation costs for delivery and installation (if applicable) of the Goods to the site of the Contracting Entity or the Contracting Entity's warehouse located at the address specified in the Special Conditions (Appendix 1).
- 3.3. The Contracting Entity will pay the price to the Contractor within thirty (30) days from the delivery date and the cumulative fulfillment of the following conditions:
 - (a) The Contractor shall submit the original of a tax invoice in accordance with the requirements of the Accounting Act; and
 - (b) The Contractor shall submit all required documents related to the Goods (where applicable) listed in tender documentation, such as, but not limited to certificates of quality, instructions for operation, installation and dismantling of the Goods, warranty and/or service book and/or any other documents related to the type of Goods and the requirements in the technical specification; and
 - (c) an inspection of the Goods performed by the Contracting Entity; and
 - (d) before the final payment to be made by the Contracting Entity, the Contractor shall provide evidence that the Contractor has paid to the subcontractor/subcontractors all due amounts in connection with the performance of this Contract in the event that the Contractor has mentioned in his tender that the Contractor will use and has used subcontractors.
- 3.4. All payments under this Contract shall only be made by bank transfer/s to an account of the Contractor specified in the Special Conditions (Appendix 1).
- 3.5. The Contractor shall immediately notify the Contracting Entity in writing of any changes in the bank information under clause 3.4. Otherwise, all payments made by the Contracting Entity shall be deemed to have been duly effected.
- 3.6. When Goods are delivered in several lots or pursuant to individual Orders of the Contracting Entity, the provisions of Art. 3.2 through Art. 3.4 shall be applicable to each individual lot or actual delivery.

4. Term of the Contract

This Contract shall be in effect for the period specified in the Special Conditions (Appendix 1).

5. Delivery terms and delivery times

- 5.1. The Contractor shall deliver the Goods to the Contracting Entity in the manner specified in the Special Conditions (Appendix 1).
- 5.2. The Contractor shall deliver the Goods to the Contracting Entity at the address specified in the Special Conditions (Appendix 1).
- 5.3. If the subject of the Contract is an estimated quantity of Goods or Goods up to a specified maximum quantity, the Contracting Entity shall not be obliged to order the supply of all Goods and the Contracting Entity shall not be liable to pay the price for them.
- 5.4. Regardless of the manner of delivery of the Goods (in full as a single lot, in several lots or pursuant to individual Orders of the Contracting Entity), the Contractor shall notify the Contracting Entity of the delivery and scheduled time in the manner, specified in the Special Conditions (Appendix 1).
- 5.5. Unless otherwise agreed by the Parties in writing, Goods shall only be accepted by the Contracting Entity between 9am and 4pm on working days. If Goods are supplied in lots, the delivery period shall be agreed by the Parties in the Special Conditions.
- 5.6. If the delivery of Goods is performed in lots or pursuant to Orders of the Contracting Entity, the times for such deliveries of Goods shall be indicated in the Special Conditions (Appendix 1) or as specified in the Purchase Order Forms." If the Contractor delivers the Goods in lots or pursuant to Orders of the Contracting Entity, unless otherwise agreed, the Contracting Entity may refuse to accept the quantity of Goods in excess of the quantities included in any lot or Purchase Order. The refusal of the Contracting Entity needs not be motivated but the Parties shall sign a certificate thereof, stating that the Contractor has delivered the Goods in quantities exceeding the contracted quantity.
- 5.7. The Contracting Entity shall send to the Contractor Purchase Orders electronically to an electronic address specified by the Contractor, by post or by courier or in any other manner agreed between the Parties. The Contractor shall confirm receipt of the Purchase Order.
- 5.8. The persons who shall represent the Contractor upon delivery of Goods shall be listed in the key personnel of the Special Conditions (Appendix 1).
- 5.9. The persons mentioned in the preceding clause can be changed by the Contractor, and the Contractor shall notify the Contracting Entity in advance in writing of such a change within five (5) days prior to delivery and acceptance of the Goods.

6. Rights of the Contracting Entity

- 6.1 The Contracting Entity has the right to receive the Goods against the contract price in accordance with the terms and conditions hereof.
- 6.2. If the Goods do not meet the Technical Specification (Appendix 2) the Contracting Entity may refuse to accept the Goods referring to Article 12.

- 6.3. If the Contracting Entity refuses to accept any Goods, the Contracting Entity shall not be liable to pay the Price or the relevant part of it.
- 6.4. The Contracting Entity may ask the Contractor to enter into a Subcontract with the Subcontractor/s mentioned in the tender of the Contractor (if the Proposal for Public Procurement Order Execution (Appendix 3) and the terms and conditions for fulfillment of the public procurement provide for it).
- 6.5. If the Contractor has provided a Performance Guarantee under this Contract, the Contracting Entity may retain or forfeit the entire Performance Guarantee or part of it provided that the Contractor has failed to fulfill in full or in part any of the provisions hereof.
- 6.6. The Contracting Entity requires from the Contractor, its employees, representatives, and its Subcontractors (if applicable) to comply with the access rules for third parties to the site of the Contracting Entity as well as to meet the requirements and obligations related to health and safety of the workers and the life and health of any other persons on the site of TPP AES Galabovo.

7. Obligations of the Contracting Entity

- 7.1. The Contracting Entity shall pay the Contractor the price of Goods supplied under the terms and conditions hereof.
- 7.2. The Contracting Entity shall render the necessary assistance to the Contractor related to the execution of this Contract and following a request in writing by the Contractor, the Contracting Entity shall provide the Contractor with any information required for that purpose.
- 7.3. Unless otherwise agreed, the Contracting Entity shall provide to the Contractor access to the place of delivery after obtaining the permits for such access, where these are required by the binding provisions.

8. The Contractor shall be entitled:

- 8.1. To obtain the Price for delivery of the Goods after their acceptance and approval without comments by the Contracting Entity under the terms and within the timeframes specified herein;
- 8.2. To obtain from the Contracting Entity the information that the Contractor needs for fulfillment of its obligations under this Contract. The request for information shall be submitted in writing.

9. The Contractor undertakes:

- 9.1. To transfer ownership of the Goods to the Contracting Entity and to deliver the Goods according to the agreed terms and timeframes;
- 9.2. To deliver to the Contracting Entity Goods of type, quality, quantity and technical data in accordance with the Technical Specification (Appendix 2) and the other requirements for delivery fulfillment;
- 9.3. To deliver the Goods to the Contracting Entity in the manner specified by the Contracting Entity - in full as a single lot, in several lots or pursuant to individual orders of the Contracting Entity;

- 9.4. To notify the Contracting Entity of the delivery in advance in accordance with the terms and conditions specified in Article 5 hereof;
- 9.5. To notify the Contracting Entity in writing as soon as possible in case it is unable to deliver the Goods in accordance with the Technical Specification (Appendix 2), the terms of completion, the agreed or ordered quantities or the delivery date;
- 9.8. To remedy at its expense by replacing or otherwise all defects, faults, errors or omissions in the Goods that might occur within the warranty period offered by the Contractor;
- 9.9. To respect and fulfill the requirements and obligations related to ensuring health and safety of the employees at the site of the Contracting Entity, and to protect the life and health of third parties at the site of TPP AES Galabovo;
- 9.10. To fulfill its obligations under this Contract with due diligence;
- 9.11. To perform its duties under this Contract without disturbing the activities of any staff and other persons working close to the site of the Contracting Entity;
- 9.12. To observe and comply with the conditions of access for third parties at the site of TPP AES Galabovo.

10. Ordering procedure

Where applicable, the Contracting Entity will send Purchase Orders/s to the Contractor.

11. Contractor warranties

11.1. The Contractor shall guarantee that the delivered Goods:

- (a) will be in full compliance with the Technical Specification (Appendix 2) and the Offered Price (Appendix 4) of the Contractor;
- (b) will meet the quality requirements according the Drawing and Technical specification;
- (c) will comply with the relevant binding regulations;

And also that for each delivery the Contractor shall apply the necessary professional experience and diligence that may reasonably be expected by a qualified and competent supplier with experience in carrying out similar supplies of similar size, scope, nature, value and complexity, and that it will invest sufficient resources for the full implementation of its obligations

11.2. The Contractor shall ensure that no third parties shall have ownership rights or any other rights or claims in respect of the Goods.

11.3. Without limitation to the provisions under clauses 11.1 and 11.2, the Contractor shall ensure that:

- (a) it will complete each delivery of Goods by the relevant delivery date;
- (b) it will always perform delivery of Goods with due diligence;
- (c) It will provide all the manpower it will ensure that all the staff employed in the delivery the Goods is qualified, trained and experienced for such delivery;

- (d) it will make delivery of Goods in full compliance with applicable legal requirements, technical specifications and requirements, which are an integral part hereof and also it will provide all necessary approvals;
- (e) it will comply with all reasonable instructions given by the Contracting Entity in connection with the delivery of the Goods;
- (f) it will fulfill the procedures and requirements of the Contracting Entity for health, safety and environmental protection introduced at the site of the Contracting Entity and it will take all necessary precautions to protect the health and safety of all persons, including its own staff, the staff of the Contracting Entity and of TPP AES Galabovo as well as the population that may be affected by the actions of the Contractor while performing delivery of Goods;

11.4. The Contracting Entity may remove the Contractor from the site of the Contracting Entity if the Contractor violates the health and safety requirements established at the site of the Contracting Entity.

11.5. The guarantee period (if applicable) for the completed delivery shall be the period specified in the Special Conditions (Appendix 1).

12. Terms and conditions for delivery and acceptance of the Goods. Claims.

12.1. Unless otherwise agreed, handover and takeover of Goods shall be done by persons designated by the Parties within the working day at the agreed place of delivery.

12.2. If during inspection of the Goods the Contracting Entity identifies any faults, defects and/or any other discrepancies of the Goods with regard to the Technical Specification (Appendix 2) and/or the Proposal for Public Procurement Order Execution (Appendix 3), the Contracting Entity shall within 60 (sixty) days from the date of delivery, notify in writing (including electronically to an e-mail address specified by the Contractor) the Contractor of any such faults, defects and/or discrepancies.

12.3. For deliveries of replaced Goods and/or Goods with removed faults, defects and/or discrepancies, the Parties shall apply the above mentioned terms and conditions for delivery.

12.4. If the Contractor has offered more favorable conditions for Goods acceptance and claims, such provisions in the tender of the Contractor shall prevail over the provisions hereof.

13. Performance Guarantee. Terms and conditions for Performance Guarantee release and retention

13.1. If the contractor has provided the Contracting Entity with a Performance Guarantee under this contract, the Contracting Entity may retain the Performance Guarantee until the Contractor executes completely, accurately and entirely this contract or until expiry of the guarantee period of the Goods.

13.2. The Performance Guarantee provided under this Contract shall be equal to the price of the Goods, specified in the Special Conditions (Appendix 1) and shall be in the form of irrevocable and unconditional bank guarantee payable at first written demand by the Contracting Entity or in the form of cash deposit into a bank account of the Contracting Entity. When it is a bank guarantee, the Performance Guarantee shall be valid one (1) month after expiry date of the contract.

13.3. The Contracting Entity may retain or forfeit the Performance Guarantee if the Contractor fails to perform any of its obligations under this Contract, including, but not limited to late



fulfillment of its obligation to deliver the Goods by more than 7 (seven) days, unless otherwise agreed.

- 13.4. The Contracting Entity may retain and forfeit the Performance Guarantee under this Contract without waiving its right to claim compensation for damage incurred in excess of the amount provided as Performance Guarantee by the Contractor.
- 13.5. Upon proper execution of this Contract by the Contractor, the Contracting Entity shall release the bond under clause 13.2 within from the completion date of the Contract (if the bond is in the form of a cash deposit), unless otherwise agreed.
- 13.6. The Contracting Entity may retain part of the Performance Guarantee (if it is a cash deposit) to secure the obligation for warranty servicing of the Goods if the Contractor has undertaken by this contract and/or by its offer to provide warranty service to the delivered Goods.
- 13.7. In the event of a dispute arising between the Parties during the execution of this contract related to a breach of the obligations made by the Contractor, the Contracting Entity may retain the Performance Guarantee (if it is a cash deposit) or may ask the Contractor to extend the validity of the issued bank guarantee until final resolution of the dispute by the competent court under this contract or by an arbitration court.
- 13.8. If this Contract is terminated or cancelled due to the Contractor's fault, the Contracting Entity may retain or forfeit the full amount of the Performance Guarantee.
- 13.9. The Contracting Entity shall not owe interest to the Contractor on the Performance Guarantee (if it is a cash deposit) for the period when the Contracting Entity has lawfully retained it.

14. Penalties and sanctions

- 14.1. If delivery is made after the date of delivery, the Contractor shall pay a penalty of 0.2% (zero point two percent) of the value of the Goods delivered late for each week of delay but not more than 5% (five percent) of the price of Goods without VAT
- 14.2. If the Contracting Entity terminates the contract due to the Contractor's fault, the Contractor shall pay a penalty of 8% of the price of Goods without VAT. The Contracting Entity shall also be entitled to compensation under the general procedure for actually suffered loss in excess of the penalty amount.
- 14.3. In case of late payment, the Contracting Entity shall pay a penalty of 0.1% (half percent) of the value of the delayed payment for each day of delay but not more than 8% (eight percent) of the value of the payment due.

15. Contract Amendment

Amendment of this Agreement shall be allowed as an exception and it shall be done by an additional agreement in writing mutually agreed between Parties in case of any precondition expressly provided for in the Public Procurement Act.

16. Invoicing

16. 1 The Contractor shall issue a tax invoice bearing the number of this contract, the order number, if applicable, containing the particulars required by the Accounting Act, and

accompanied by the supporting information required under the Contract or by the Contracting Entity. Invoices shall be prepared and accepted under the procedure for sending and accepting of invoices (Appendix 6). If the provisions of clause 3.3 hereof are fully and precisely fulfilled, the Contracting Entity shall pay the amount indicated in the invoice within the specified payment period.

- 16.2. If the Contractor makes a wrong payment to the Contractor including wrongly charged VAT, the Contractor shall immediately reimburse that amount to the Contracting Entity.
- 16.3. Payments by the Contracting Entity under this Contract are not subject to tax, except VAT and deductions provided by law. In particular, if any payment under this Contract is subject to withholding tax at source, the Contracting Entity shall withhold the tax from the payment amount and pay it to the account of the National Revenue Agency. In these circumstances, payments to the Contractor will represent amounts due under this Contract, reduced by the withholding tax under the law. It is the duty of the Contractor to prove the reasons for not withholding tax at source.

17. Assignment

- 17.1 The Contractor shall not, without the prior written consent of the Contracting Entity, transfer or otherwise dispose of its rights under this Contract.
- 17.2 Contractor shall be responsible to ensure quality of the work and observance of the safety requirements by the staff of its subcontractors. The Contractor shall designate competent persons to supervise the performance of the subcontractors.
- 17.3 The Contractor shall be entitled to make inspections and checks to the work on site and make audits to subcontractors following the procedure by which they are carried to the Contractor.

18. Ownership

- 18.1. Subject to Article 18.3 and in view of the specific conditions of each delivery and passing the risk specified herein, ownership of Goods shall pass from the Contractor to the Contracting Entity at the time of delivery or payment by the Contracting Entity (if for some reason payment precedes delivery).
- 18.2. Subject to Article 18.3 and in view of the specific conditions of delivery and passing the risk specified herein when the Contractor receives Goods from a third party, the Contractor shall ensure that ownership of the Goods is transferred to the Contracting Entity at the time of delivery or payment by the Contracting Entity (if for some reason payment precedes delivery).
- 18.3. If payment is made by the Contracting Entity before delivery, and in view of the specific conditions of delivery and passing the risk specified herein, ownership of the Goods shall be transferred by the Contractor to the Contracting Entity as soon as Goods can be identified, but the risk of loss or damage shall not pass onto the Contracting Entity before the time of delivery. Such advance payment shall not be construed as meaning that the Goods have been approved by the Contracting Entity.

19. Intellectual property licenses and confidentiality

- 19.1. The Contractor shall ensure that delivery and use of the Goods will not break any patent, registered design, copyright, trademark or other intellectual property rights ("**Protected Rights**"). Unless the Contracting Entity has agreed otherwise, the Contractor shall provide to the Contracting Entity an irrevocable, royalty-free non-exclusive license for such use

from third parties when such is necessary for making full use of the Goods and their features.

- 19.2. The Contractor shall indemnify the Contracting Entity in case that the Contracting Entity is held liable for violation of any protected rights in connection with the use of the Goods.
- 19.3. The Contractor shall keep all the information and software related in any way with the Contracting Entity, as most strictly confidential and the Contractor shall not to use or disclose them except for the purposes hereof, without the prior written consent of a person authorized by the Contracting Entity.
- 19.4. If any specific conditions under this Contract arise, the Contractor shall immediately obtain all necessary permits for import and export and all other approvals required for the delivery of Goods.

20. Risk, liability and insurance

- 20.1. The Contractor shall indemnify the Contracting Entity for all damages related to loss or damage to property of the Contracting Entity or third party, as well as costs for removing spills of chemical substances and mixtures, including adverse environmental footprint impacts of them arising out of or in connection with fulfillment or non-fulfillment of the obligations of the Contractor under this Contract, unless such a liability arises out of or in connection with intentional acts or gross negligence on the part of the Contracting Entity or its representatives.
- 20.2. The Contractor shall indemnify the Contracting Entity for all direct costs and claims (including for loss of or damage to property and injury or death of a person) suffered by the Contracting Entity as a result of violation hereof or any other infringement action or omission (including negligence) of the Contractor or a person for whom the Contractor bears responsibility.
- 20.3. Contractor shall be liable for any loss or damage to the Goods until their delivery to the Contracting Entity, except in the cases where this Contract provides for passing of the risk otherwise. The Contractor shall be liable for any loss or damage to the Goods during the whole period of time (e.g. their stay in the warehouse of the Contractor or within the guarantee period during which the Contractor shall take care of the Goods and check them.
- 20.4. The Contracting Entity shall not be responsible for the damage and loss of plant, materials and equipment of the Contractor and the risk for them shall be borne by the Contractor.
- 20.5. The Contractor agrees and hereby accepts full and sole responsibility for withholding and paying any and all taxes, contributions, etc., to which it and its Subcontractors are subject to tax with respect the Unemployment Fund and also the contributions towards social, pensions insurance, pensions and the like, imposed by the existing and any future regulations of the authorities in terms of wages, salary or other remuneration payable to the staff employed by the Contractor in connection with the delivery of the Goods and other contractual work.
- 20.6. The Contractor shall in no event be liable for any indirect damages, loss of profit and consequential damages arising from or in connection with this Contract, such as including but not limited to loss of production, business interruption, loss of use, financing expenditure, loss of interest or any other additional costs in connection with business interruption.

21. Terms and conditions for termination / cancellation of the contract

21.1. This Contracts terminates:

- (a) upon expiry of the term under Article 4 of the Contract;
- (b) upon its final completion;
- (c) by mutual agreement of the Parties expressed in writing;
- (d) by the Contracting Entity upon occurrence of an unforeseen event mentioned in Article 43, para. 4 of PPA, making it impossible for the Contracting Entity to fulfill its obligations under the Contract;
- (e) upon any transformation of the Contractor in accordance with the law of the country, in which it has been established in the event that its successor does not meet the conditions laid down in the legislation for continuation of the procurement contract;
- (f) in case of any other grounds for termination of the procurement contract provided for in the legislation.

21.2. The Contracting Entity may unilaterally terminate the contract without notice if the Contractor:

- (a) delays the execution of any of its obligations under this Contract for more than 7 (seven) days;
- (b) refuses to replace the Goods showing faults, defects and discrepancies within the time specified by the Contracting Entity;
- (c) refuses to remedy at its expense faults, defects and discrepancies identified in the delivered Goods within the time frame specified by the Contracting Entity;
- (d) fails to fulfill accurately and in full compliance any of its obligations under this Contract and its appendices;
- (e) uses Subcontractor/s for execution of this Contract without declaring this fact in its tender or uses Subcontractor/s which is/are not mentioned in its proposal unless expressly permitted by PPA;
- (e) in case of insolvency proceedings initiated against the Contractor or termination of its commercial activity due to liquidation under the national law of the country in which the Contractor is registered.

21.3. The Contractor shall not be entitled to compensation or offset for expenses incurred or arising after Contract termination, save for costs resulting directly and immediately from the termination of delivery, if the Contracting Entity has given its prior written consent for incurrence of such expenses.

22. Non-exclusivity

Nothing herein shall be construed as prohibiting the Contractor or the Contracting Entity from entering into similar contracts or other agreements with any other companies, partners or parties.

23. Severability

All provisions herein are separate and different from one another and if for some reason one or more of these provisions are rendered invalid or unenforceable, it shall be deemed to be

isolated and deleted from this Contract, in which case the other provisions of the Contract shall remain in full effect.

24. Notices

All notices delivered in connection with this Contract shall be in English and in writing. Notices can be delivered in person to the contact persons by e-mail or by mail with return receipt to the address specified herein unless such an address has been changed, for which the relevant Party has informed the other one.

25. Entire agreement

This Contract contains all the issues on which the Parties have agreed and reached understanding on the subject matter of this Contract and supersedes any and all prior negotiations, obligations and correspondence in connection with the subject matter of this Contract, unless the applicable law provides otherwise

26. Governing law and disputes

Any and all disputes arising out or in connection with this Contract shall be settled by the two parties with mutual agreement.

Appendixes:

1. Special Conditions;
2. Technical Specification;
3. Technical Proposal;
4. Offered Price;
5. Agreement for ensuring healthy and safe working conditions;
6. Procedure for sending and accepting of invoices.

Signed for and on behalf of **AES – 3 C Maritza East I EOOD**

Signature:

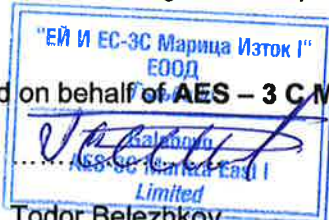

The image shows a blue ink signature of Todor Belezhkov over a blue rectangular stamp. The stamp contains the text: "ЕЙ И ЕС-3С Марица Изток I" (top), "ЕООД" (middle), and "AES - 3 C Maritza East I Limited" (bottom).

Name:

Todor Belezhkov

Title:

Plant Manager AES Bulgaria

Signed for and on behalf of **Maschinenfabrik Liezen und Gießerei Ges.m.b.H**

Signature:



A blue ink signature of i.V. Kreuzbichler Rene.



A blue ink signature of i.A. Schachner Andrea.

Name:

i.V. Kreuzbichler Rene

i.A. Schachner Andrea

Title:

Head of sales department

Sales department

Foundry division

Foundry division

Appendix 1
Special Conditions

Contracting Entity	AES – 3 C Maritza East I EOOD UIC: 123533834; VAT number: BG123533834
Contracting Entity's address	Galabovo 6280, Galabovo Municipality, Stara Zagora region, Bulgaria
Contracting Entity's Representative	Name: Dimo Kolev Bahov Telephone number: +359 885263254 E-mail: dimo.bahov@aes.com
Contracting Entity's Key Personnel	1. Technical matters: Name: Milen Stoyanov Telephone number: +359 884377622 E-mail: milen.stoyanov@aes.com 2. Accounting matters (invoices): E-mail: emea.apinvoices@aes.com 3. Commercial and contract matters: Name: Denitsa Tsoneva Telephone number: +359 42 901518 E-mail: denitsa.tsoneva@aes.com 4. Health & Safety Coordinator: Duty engineer H&S: 0884 886663 E-mail: MaritzaEHSTeam@aes.com
Contractor	Maschinenfabrik Liezen und Gießerei Ges.m.b.H VAT No.: ATU 37070209
Contractor's address:	Werkstraße 5, 8940 Liezen - Austria
Contractor's Representative	Name: Kreuzbichler Rene Telephone number: + 3612 270 1522 E-mail: r.kreuzbichler@mfl.at
Subject of Contract	Supply of primary beaters for coal mills type N440.41V
Contractor's Key Personnel	Quality department Name: Bischof Franz Telephone number: + 3612 270 1504 E-mail: f.bischof@mfl.at

	<p>Sales department</p> <p>Name: Schachner Andrea</p> <p>Telephone number: + 3612 270 1243</p> <p>E-mail: a.schachner@mfl.at</p>
Article 3.1 Price of Goods	<p>The Price of Goods - primary beaters (subject matter of this Contract) is as follows:</p> <p>Total price - EUR 43.586,95 (forty three thousand five hundred eighty six Euro and ninety five Euro cents) VAT excluded, for DAP delivery on the site of the Contracting Entity as per INCOTERMS 2015.</p> <p>The Contracting Entity shall pay the price for each delivery within 30 (thirty) days after submission of an invoice original and an acceptance certificate signed without comments by the representative of the Contracting Entity and after meeting the requirements under Article 3.3 of the Contract.</p>
Article 3.4 Bank account indicated by the Contractor	<p>Bank: Raiffeisen Landesbank Oberosterreich</p> <p>IBAN: AT79 3400 0000 0008 4400</p> <p>BIC: RZOOAT2L</p>
Article 4 Term of the Contract	<p>The Contract shall come into effect on the date of signature and shall be valid for 5 (five) months.</p>
Article 5.1 Goods Delivery Terms	<p>The primary beaters shall be delivered in lots according to the date for delivery specified in the Technical Offer (Appendix 3) in accordance with the applicable regulatory requirements. Each delivery shall be accompanied by:</p> <ul style="list-style-type: none"> (a) Acceptance certificate; (b) Certificate of Quality; (c) Declaration of conformity and Certificate of Quality for materials used
Article 5.2 Address for delivery of the Goods	<p>The Goods shall be delivered to the site of the Contracting Entity.</p>
Article 5.4 Way of notification of the delivery date and scheduled time	<p>Notice of readiness for shipment shall be sent to the Contracting Entity at least one (1) day prior to the date of shipment to the email address&: <u>store@aes.com</u></p>
Article 11.5 Guarantee period	<p>24 (twenty four) months as from the delivery date.</p>

<p>Article 13 Performance Guarantee. Terms and conditions for Performance Guarantee release and retention</p>	<p>Not applicable</p>
<p>Article 14 Penalties and Sanctions</p>	<p>In case of delay in the execution of the Contract by more than 3 (three) Working Days, the Contracting Entity shall be entitled to compensation under the general procedure for actually suffered loss in excess of the penalty amount.</p> <p>For actually suffered loss in excess of the penalty amount agreed, the concerned Party may seek compensation in full by arbitration.</p>
<p>Article 20.5 Insurance</p>	<p>Not applicable</p>

Appendix 2
Technical Specification

Appendix 3
Technical Proposal

Appendix 4
Offered Price

Appendix 2

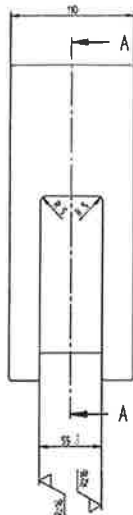
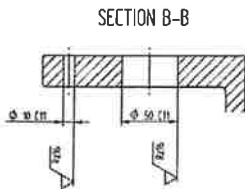
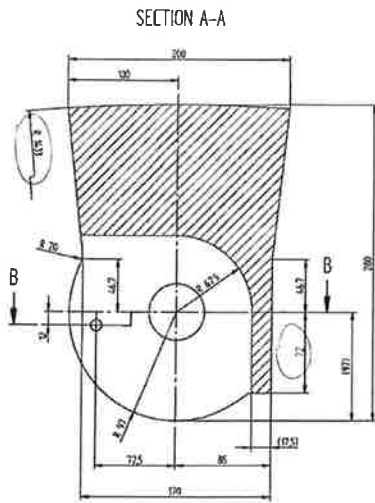

$\sqrt{\quad}$ ($\sqrt{Rz 16}$)

nicht bemessene Radien R = 25
not dimensioned radii R = 25

hierzu Stückliste Nr.
to this parts lists ALSTOM no

14815/00 370-2023

Z. SUKSESSY		Partikel	Artik.	Bezeichnung	Zeichnung	Material	Material	Material	Material
1		14815/00	000000	000000	000000	000000	000000	000000	000000
Bsp. (Material Code)		Created by	Checked by	Approved by	Drawn by	Checked by	Approved by	Drawn by	Checked by
Project Name: Maritz East I Power Station									
Company (Manufacturer):									
Specify the name of Manufacturer of Castings Mark as noted on Drawing and notes					Specify the name of Supplier Mark as noted on Drawing and notes				
Area for stamp of ESOE (EN 10204) Mark as noted on ESOE Certificate (EN 10204)					Specify the name of authorized Supplier Design Mark as noted on Manufacturer's Part Approval Process				
Specify the name of the Contractor / Engineer as shown on drawings									

Tolerances	
Castings	: GTB 17 DIN 680, Bl. 1 + 2
Welded fabrications	: NF ISO 15920
All other dimensions	: surface DIN ISO 2768
Surface symbols	: DIN ISO 1302
Geometrical tolerancing	: DIN ISO 1101
Dimensions which are to be adhered to	
Formtolerances	
Gefügefehler	: GTB 17 DIN 680, Bl. 1 + 2
Schweißkonstruktionen	: NF ISO 15920
alle übrigen Maße	: nach DIN ISO 2768
Oberflächenzeichen	: DIN ISO 1302
Form- und Lagehinweise	: DIN ISO 1101
Maße werden protokolliert	

Approved by:	Checked by:	Checked by:	Approved by:	Approved by:
Signature	Signature	Signature	Signature	Signature
Date	Date	Date	Date	Date
14815/00 370-2023	14815/00 370-2023	14815/00 370-2023	14815/00 370-2023	14815/00 370-2023
ALSTOM	ALSTOM	ALSTOM	ALSTOM	ALSTOM
ALSTOM Power Grid	ALSTOM Power Grid	ALSTOM Power Grid	ALSTOM Power Grid	ALSTOM Power Grid

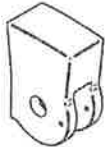

Appendix 3

ОБРАЗЕЦ
TEMPLATE

Maschinenfabrik Liezen und Gießerei Ges.m.b.H., Werkstraße 5, 8940 Liezen - Austria, ph. +43 3612/270-1243, ATU 37070209, Austria

/пълно наименование на участника, търговски адрес, телефон и факс, ЕИК и ИН по ЗДДС/
/Participant's full name, commercial address, telephone and fax, UIC and VAT registration number/

ТЕХНИЧЕСКО ПРЕДЛОЖЕНИЕ
TECHNICAL OFFER

към Оферта за участие в обществена поръчка с предмет: „Доставка на чукове за въглищни мелници тип N440.41V“
a part of the Offer for participation in a direct negotiations procedure with subject: "Supply of primary beaters for coal mills type N440.41V,
Ref. ME1-2017-DN-D-010

№	Наименование и техническо описание Name and technical description	Мерна едница Unit	Кол-во Quantity	Производител и страна на произход Manufacturer and country of origin	Срок на доставка Delivery date/time	Гаранционен срок след доставка Warranty period after date of delivery	Забележка Notes
1	2	3	4	5	6	7	8
1	Primary Beater, art. No 10.313.826	бр. / pcs	59	Austria	cw 13/2017	24 months	
2	Primary Beater, art. No 10.313.826	бр. / pcs	191	Austria	cw 24/2017	24 months	

Срок на валидност на офертата: 90 календарни дни
Validity of offer: 90 calendar days

Документи, придружаващи стоката при доставка:
Documents accompanying the goods during shipment:

- Приемо-предавателен протокол; Acceptance Certificate;
- Сертификат за качество; Certificate of Quality
- Декларация за съответствие и Сертификат за качество на използваните материали; Declaration of Conformity and Certificate of Quality for materials used

ПОДПИС и ПЕЧАТ: / SIGNATURE AND STAMP:

i.V. Kreuzbichler Rene, i.A. Schächner Andrea (име и фамилия) / (name and surname)

21.02.2017 (дата) / (date)

Head of sales department foundry; Sales department foundry (длъжност на управляващия/представяващия участника) / (title of Participant's manager/representative)

MASCHINENFABRIK LIEZEN

UND GIEßEREI GEBMEN m.b.H. (наименование на участника) / (Participant's name)

A - 8940 LIEZEN

Appendix 4

ОБРАЗЕЦ
TEMPLATE

Maschinenfabrik Liezen und Gießerei Ges.m.b.H., Werkstraße 5, 8940 Liezen - Austria, ph. +43 3612/270-1243, АТУ 37070209, Austria
/пълно наименование на участника, търговски адрес, телефон и факс, ЕИК и ИН по ЗДДС/
/Participant's full name, commercial address, telephone and fax, UTC and VAT registration number/

ЦЕНОВА ОФЕРТА / PRICE OFFER

към Оферта за участие в обществена поръчка с предмет: „Доставка на чукове за въглищни мелници тип N440.41V“
a part of the Offer for participation in a direct negotiations procedure with subject: "Supply of primary beaters for coal mills type N440.41V,
Ref. ME1-2017-DN-D-010

№	Наименование и техническо описание Name and technical description	Мерна единица Unit	Кол-во Quantity	Единична цена, Евро без ДДС Unit Price EUR, VAT excl.	Обща цена, Евро без ДДС Total price EUR, VAT excl.
1	2	3	4	5	6
1	Primary Beater, art. No 10.313.826	бр. / pcs	250	179,74	44.935,00
Ценава оферта в Евро без ДДС: PRICE OFFER in EUR without VAT:					44.935,00

ПОДПИС и ПЕЧАТ: / SIGNATURE AND STAMP:

i.V. Kreuzbichler Rene; i.A. Schachner Andrea (име и фамилия) / (name and surname)

21.02.2017 (дата) / (date)

Head of sales department foundry, Sales department foundry (длъжност на управляващия/представяващия участника) / (title of Participant's manager/representative)

MASCHINENFABRIK LIEZEN
UND GIEßEREI GESMBH. (наименование на участника) / (Participant's name)

UND GIEßEREI GESMBH.

A - 8940 LIEZEN

Appendix 11

MFL-Maschinenfabrik Liezen und Giesserei Ges.m.b.H., A-8940 Liezen/Austria

AES
3C Maritza East 1 EOOD
6280 GALABOVO
BULGARIA

Offer

Our reference number / Date
A2307451 / 21.02.2017
Expert / Phone-Ext. / Fax-Ext. / e-mail
Mrs. Schachner / 1243 / 1592
a.schachner@mfl.at
Your reference number / Date / Name
56229 / 10.02.2017
Mrs. Tsoneva
Client number
2774432
Validity
until 31.03.2017

1st. revision: Discount

Dear Mrs. Tsoneva,

we thank you for your inquiry and are pleased to submit you our offer according to the General Conditions of Contracting for European Foundries, Edition 2013, as follows:

Pos.	Article no. Description	Quantity	Price in EUR	Price unit	Total price in EUR
0010	42607909 Primary beater	250,00 PCS L 6079	179,74	1 PCS	44.935,00
	raw part: drawing nr. AES: 1.48115/00 370-0023 Rev.2 3D data AES: - weight: 30,80 kg/Stk. material: GE 300 N acc. DIN EN 10293 ***** as deliverd ***** Special Discount % -3,000 %				-1.348,05

Anschrift/Address:

Werkstraße 5
A-8940 Liezen
AUSTRIA

Telefon/Phone: +43 3612 270-DW/Ext.
Telefax: +43 3612 270-DW/Ext.
Web Site: <http://www.mfl.at>

UID-Nr./VAT Reg.no.: ATU 37070209
Firmenbuch-Nr./Commercial Register:
127 024 a - Leoben
Gerichtsstand/Jurisdiction: Graz, Austria

Reservation of ownership:

Until full payment the goods remain the property of MFL-Maschinenfabrik Liezen und Giesserei Ges.m.b.H.

EN 10904



DNV
Certified
Company

Total value in EUR: 43.586,95

Date of delivery: cw 24/2017

Terms of delivery: DAP Galobovo (acc. to Incoterms 2010)

Terms of payment: 30 days net

(Basis for the terms of payment is the date of invoice)

Liability:

The parties are liable for damages only in the cases that are expressly agreed upon in the contract or in case of gross negligence or insofar they are insured resp. usually can be insured.

Secured rights:

MFL will be held free of any claims of third parties which derive from infringements of patents, copyrights, secured or other rights under legal protection.

We hope that our offer meets your expectations and would be very pleased to receive your esteemed purchase order.

We are looking forward to hearing from you.

Best regards

MASCHINENFABRIK LIEZEN
UND GIESSEREI GES.M.B.H.



i.V. Mag. R. Kreuzbichler
Head of sales department/
Foundry Division

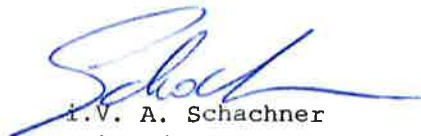

i.V. A. Schachner
sales department
Foundry Division

Anschrift/Address:

Werkstraße 5 Telefon/Phone: +43 3612 270-DW/Ext.
A-8940 Liezen Telefax: +43 3612 270-DW/Ext.
AUSTRIA Web Site: <http://www.mfl.at>

UID-Nr./VAT Reg.no.: ATU 37070209
Firmenbuch-Nr./Commercial Register:
127 024 a - Leoben
Gerichtsstand/Jurisdiction: Graz, Austria

Reservation of ownership:

Until full payment the goods remain the property of MFL-Maschinenfabrik Liezen und Giesserei Ges.m.b.H.

EN ISO 9001



DNV

Certified
Company

Appendix 5

AGREEMENT

on the rights and obligations of the Parties and on coordination of measures to ensure health and safety at work

1. Subject of the Agreement

- 1.1. This agreement establishes the requirements, rights and obligations of the parties to ensure health and safety at work of their workers and to protect the life and health of others who are in the area of their activities on the territory of the Contracting Entity.

2. General requirements

- 2.1. The employees of the Contracting Entity and the Contractor who organize and manage work processes shall be responsible for ensuring health and safety at work of the workers involved in the activities they manage. They shall immediately inform each other of all dangers and hazards.
- 2.2. No other activities except the agreed ones can be performed on the worksite or, by exception, activities subject to prior written permission by the Contracting Entity after special instruction of the Contractor's employees.
- 2.3. Movement of workers on site shall take place along designated routes, care being taken of any uneven surfaces, open shafts, moving vehicles and other marked or unmarked dangers threatening life and health.
- 2.4. If an activity is performed by employees of the Contracting Entity and of the Contractor in a single room and/or at two levels, the persons mentioned in Article 1 hereof shall take measures to ensure their mutual safety.
- 2.5. During work access shall be prohibited to any unauthorized persons who are not directly involved in the performance of the agreed activities.
- 2.6. Equipment, ladders and platforms used for work at height shall be standard and shall meet all safety requirements.
- 2.7. When carrying out hot works, employees of the Contracting Entity and the Contractor shall observe the fire safety rules. Smoking on the premises of the Contracting Entity is only allowed in the designated areas.
- 2.8. In case of or likelihood of occurrence of serious and imminent danger to life and health, the employees of the Contracting Entity and the Contractor shall immediately stop work until danger is eliminated.
- 2.9. During the execution of all works and activities under the Contract, the relevant applicable regulations and internal rules on health and safety at work shall be equally binding on both Parties.
- 2.10. Losses caused by worsening of quality and extending the timeframes of the performed work due to the dismissal of individuals or suspension of groups/teams for violations of the requirements under the rules and instructions on labor safety, industrial fire safety and environmental protection shall be at the expense of the Contractor.
- 2.11. Upon persistent breaches of the health and safety requirements by the Contractor, the Contracting Entity may unilaterally terminate the contract without owing any compensation to the other Party.

3. Rights and obligation of the Contracting Entity

- 3.1. Before commencement of the contractual work, the Contracting Entity shall conduct initial instruction and instruction at the worksite (if required) to the Contractor's staff as required by Ordinance RD-07-2 of 16 December 2009 on the conditions and procedures for conducting periodic training and instruction of employees on the rules to ensure healthy and safe working conditions, it records them in the relevant log. Conducting of all other types of instruction is the responsibility of the Contractor.
- 3.2. The Contracting Entity shall require from the Contractor a list of the names, certification documents (if required for a specific job) and certificates of acquired qualification group for all persons who will work on site and in the premises of the Contracting Entity.
- 3.3. The Contracting Entity shall provide safe access of employees and vehicles of the Contractor to the worksite for the duration of the Contract.
- 3.4. The Contracting Entity shall make the employees of the Contractor who organize and manage work processes familiar with the location of the serviced facilities, the specific characteristics of the worksite and the occupational hazards.
- 3.5. The Contracting Entity shall ensure the implementation of organizational and technical measures before admission of the Contractor's staff to work and also designate their worksites.
- 3.6. The Health and Safety Department (hereinafter referred to as HS) of the Contracting Authority is authorized to carry out monitoring for compliance with the requirements of safety and health at work. The instructions of its employees are binding to the Contractor's staff.
- 3.7. The Contracting Entity may dismiss from the worksite any Contractor's employees who are not familiar with the rules for health and safety at work, who do not observe them or do not have the necessary capacity, and also in case of serious and immediate risk to their health and life.
- 3.8. The Contracting Entity shall provide assistance to the Contractor including specialized equipment and staff in case of accidents, fires and/or incidents due to its fault.
- 3.9. the Contracting Entity shall duly inform the Contractor of any internal orders and decisions of the task forces related to its safety at work.

4. Rights and obligations of the Contractor

- 4.1. The Contractor shall provide qualified staff for the safe execution of the contractual activities.
- 4.2. The Contractor shall ensure that the persons who will carry out contractual activities are present at the initial instruction held prior to work commencement and at the instruction on the worksite as well as at any other instructions conducted by the Contracting Entity.
- 4.3. Before conduction of the initial instruction by the Contracting Entity, the Contractor shall submit a list of the names and the qualification group of each person, including the job managers and performers and the safety persons who will work on the site of the Contracting Entity.
- 4.4. When performing activities that require additional qualifications under the applicable regulations, the Contractor shall also furnish to the Contracting Entity the relevant qualification documents of its staff.

- 4.5. The Contractor's staff shall while at work have on them their certificates of acquired qualification group in safety, as well as all documents proving the acquired qualifications.
- 4.6. The contractor is solely responsible for the provision and use of personal protective equipment by its employees.
- 4.7. The Contractor shall be responsible for the proper use of personal and collective protective equipment by its employees.
- 4.8. The Contractor shall ensure that its staff observes the instructions given by the Contracting Entity as well as the rules for health and safety at work and the relevant internal regulations in this regard.
- 4.9. The Contractor's staff may not commence work on the site of the Contracting Entity without any authorization by the authorized persons of the Contracting Entity.
- 4.10. The Contractor shall not allow removal of signs and fences, and also the Contractor may not carry out activities outside the designated worksite or block passages, corridors and platforms with dismantled assemblies, spare parts, waste materials and the like..
- 4.11. When performing the contractual activities, the Contractor shall not hinder the operational personnel to carry out safety walks and maintenance of the operating equipment and the redundant equipment items.
- 4.12. The Contractor shall ensure that its employees use appropriate tools in good condition and safe working equipment including proper and safe use of vehicles and the Contractor shall prevent them from using vehicles that are out of order.
- 4.13. The Contractor shall ensure that its staff appears to work after having good rest and shall not allow the use of alcohol or other intoxicating substances during the working hours as well as work under their influence.
- 4.14. The Contractor shall not allow persons to perform work, which they are not familiar with or do not possess relevant qualifications and competence.
- 4.15. The Contractor shall immediately inform the relevant employees of the Contracting Entity of any situation arising at work which might pose a serious and imminent danger to workers.
- 4.16. The Contractor may refuse to execute a certain job if there are reasonable doubts about the conditions related to health and safety of the workers provided by the Contracting Entity. The Contractor shall immediately notify the HS Department of the Contracting Entity about this situation.
- 4.17. In case of incidents and accidents with persons from the Contractor's staff, the head of the team shall immediately notify their management and the HS Department of the Contracting Entity, and then take measures and provide assistance in clarifying the circumstances and reasons of the accident.
- 4.18. The Contractor shall keep its worksites tidy, clean and safe. Upon completion of each portion of the work, the Contractor shall immediately remove from the worksite all of its plant, construction equipment, temporary structures and waste materials that will not be used at or near the same place during the later stages of work.
- 4.19. Contractor may at its discretion and in accordance with the regulations require additional measures to ensure safety at work.

5. Other conditions

5.1. The employees authorized by the Contracting Entity, upon identification of any breaches of the rules on labor safety made by the Contractor's staff, may:

- (a) give instructions or prescriptions for remedy of such breaches;
- (b) dismiss individual members or groups (teams) by stopping work if the breaches impose it;
- (c) give the Contractor suggestions in writing for sanctioning of persons who have made violations on the site of the Contracting Entity.

This supplementary Agreement prepared to meet the requirements of Article 14, Article 16, Article 18, Article 19 of the Health and Safety at work Act is an integral part of **CONTRACT** MB...L...PPL and it shall be in effect until expiry of the Contract.

Signed for and on behalf of the Contractor:

Signature: 
.....

Name: i.V. Kreuzbichler Rene

Title: Head of sales department

Foundry division

Date: 24.3.17
.....

.....

i.A. Schachner Andrea

Sales department

Foundry division

Appendix 6

Procedure for sending and acceptance of invoices

1. **Hard copy documents shall be sent by post to:**

„AES Europe Services“ EOOD

Department: Processing of Incoming Invoices

1407 Sofia, j. k. Sredetz, Bulgaria

Blvd. „Cherni Vrah“ 32A, Aries Office Building, floor 1

Important: According to the Bulgarian tax requirements subject to processing are only original invoices. Scanned copies sent to the address emea.apinvoices@aes.com will be processed only if they are stamped and signed by the supplier with a "True copy".

2. **Electronic invoices shall be sent to the common email address:**

emea.apinvoices@aes.com

Issuing and sending your electronic invoices to this common email address will greatly contribute to more rapid and efficient processing of your documents and payment.

Please, consider in this case the following particulars, which are also a prerequisite for the efficient processing of documents:

- (a) Invoices shall be in Adobe PDF format;
- (b) If you are sending several invoices, you can attach just one invoice to an e-mail, so you will have to send as many e-mails as is the number of your invoices;
- (c) Each invoice can consist of more than one page;
- (d) Protocols shall be added as additional pages to the invoices;
- (d) Include in the Subject of your e-mail with an attached invoice to it the key word "Фактура" in Bulgarian or "Invoice" in English, for automatic and faster processing by the system;
- (e) If you have issued and sent an electronic invoice, you do not need to re-send a hard copy.

3. **Hand-written invoices**

If you still issue hand-written invoices, we would like to inform you that they cannot be read by the electronic scanning and automatic recognition system and since they need manual processing there might be some delays in their accounting and payment.

The Contracting Entity strongly recommends to you to avoid issuing hand-written invoices for your more efficient servicing!

TO:

AES – 3C Maritza East I EOOD

Galabovo 6280 | P.O. Box 600 | Bulgaria

Confirmation

With this letter MFL confirms that

- the criminal record reports from our representatives (Haider Reinhard, Decker Herbert, Haindl Wolfgang) not contain any entries
- MFL has not violated Austrian Labour legislation. It means that the company pays the employees regularly and there is no court cases for breaching Labour law obligations.



i.V. R. Kreuzbichler
Head of sales department/
Foundry Division



i.A. A. Schachner
Sales department
Foundry division

Landesgericht Leoben, Sitz: Liezen
FN 127 024 a
UID-Nr.: ATU 37070209
DVR: 0485730

Railfeisen Landesbank Oberösterreich
Kto Nr.: 84.400, BLZ 34000
IBAN: AT79 3400 0000 0008 4400
BIC: RZ00AT2L